

**ATOMIC ENERGY CENTRAL SCHOOL-2, MUMBAI**  
**PERIODIC TEST-3, 2023-24**  
**(10.01.2024)**

**Class: X**

**Time : 90 min**

**Subject: SCIENCE**

**Max Marks: 40**

**General instructions:**

1. The question paper comprises of three sections A, B, C and D. All questions are compulsory. Attempt all the sections.
2. Section A has 10 Multiple choice questions and each question carries 1 mark.
3. Section B has 3 questions and each question carries 2 marks.
4. Section C has 4 questions and each question carries 3 marks.
5. Section D has 3 questions and each question carries 4 marks
6. Wherever necessary, neat and properly labelled diagrams should be drawn.

**SECTION- A**

**I. Choose the correct options from the following choices given.**

**(1x10=10)**

1. In an electrical circuit two resistors of  $2\ \Omega$  and  $4\ \Omega$  respectively are connected in series to a  $6\ \text{V}$  battery. The heat dissipated by the  $4\ \Omega$  resistor in  $5\ \text{s}$  will be

- (a)  $5\ \text{J}$
- (b)  $10\ \text{J}$
- (c)  $20\ \text{J}$
- (d)  $30\ \text{J}$

2. The strength of magnetic field inside a long current carrying straight solenoid is

- (a) more at the ends than at the centre
- (b) minimum in the middle
- (c) same at all points
- (d) found to increase from one end to the other

3. If the current  $I$  through a resistor is increased by 100% (assume that temperature remains unchanged), the increase in power dissipated will be

- (a) 100 %
- (b) 200 %
- (c) 300 %
- (d) 400 %

4. Oxides of moderately reactive metals like Zinc, Iron, Nickel, Tin, Copper etc. are reduced by using

- (a) Aluminium as reducing agent
- (b) Sodium as reducing agent
- (c) Carbon as reducing agent
- (d) Calcium as reducing agent

5. Alcohols can be produced by the hydration of

- |            |              |
|------------|--------------|
| a) Alkanes | b) Alkenes   |
| c) Alkynes | d) Aldehydes |

6. Which of the following belongs to homologous series of alkynes?

$C_6H_6$ ,  $C_2H_6$ ,  $C_2H_4$ ,  $C_3H_4$ .

- (a)  $C_6H_6$
- (b)  $C_2H_4$
- (c)  $C_2H_6$
- (d)  $C_3H_4$

7. Which of the following is an example of genetic variation?

- (a) One person has a scar, but his friend doesn't
- (b) One person is older than the other
- (c) Reeta eats meat, but her sister Geeta is a vegetarian
- (d) Two children have different eye colour

Question No.8 ,9 and 10 consist of two statements – **Assertion (A)** and **Reason (R)**. Answer the question selecting the appropriate option given below:

- a) Both Assertion and Reason are true and Reason is the correct explanation of Assertion.
- b) Both Assertion and Reason are true but Reason is not the correct explanation of Assertion.
- c) Assertion is true but Reason is false.
- d) Assertion is False but Reason is true.

8. **Assertion:** Alloys are commonly used in electrical heating devices like electric iron , toasters .

**Reason:** Alloys do not oxidise(burn) easily at high temperatures.

9. **Assertion:** Variation is high in sexually reproducing organisms compared to asexually reproducing organisms.

**Reason:** Inaccuracies during DNA copying give rise to variation.

10. **Assertion:** Carbon compounds can form chain, branched and ring structures.

**Reason:** Carbon exhibits the property of catenation.

## SECTION – B

**III. Answer the following questions. (2x3=6)**

- 11 What does the direction of thumb indicate in the right-hand thumb rule. In what way this rule is different from Fleming's left-hand rule?

12. Intake of a small quantity of methanol can be lethal. Comment.
13. In the following food chain, 500J of energy is available to plant. How much energy will be available at I consumer and II consumer levels?

Plant → Sheep → Man

### SECTION – C

#### IV. Answer the following questions in three to four sentences

(3x 4=12)

14. (a) What is an electric fuse? Write its function.  
(b) What is the function of an earth wire? Why is it necessary to earth metallic appliances?
15. A cross was made between pure breeding pea plants, one with round and green seeds and the other with wrinkled and yellow seeds.  
(a) Write the phenotype of  $F_1$  progeny. Give reason for your answer.  
(b) Write the different types of  $F_2$  progeny obtained along with their ratio when  $F_1$  progeny was selfed.
16. In the following food chain, plants provide 500 J of energy to rats. How much energy will be available to hawks from snakes?

Plants → Rats → Snakes → Hawks

Draw a food chain with four trophic levels.

Which of the following are always at the second trophic level of food chains?

Carnivores, Autotrophs, Herbivores

17. The electronic configuration of three elements X, Y and Z are as follows: X=2,4; Y=2,7; Z=2,1

- (a) Which two elements will combine to form an ionic compound and Why?
- (b) Write its chemical formula .
- (c) Which type of bond will the third element form and why?

### SECTION – D

**IV .** Read the given passage and answer the questions based on the passages and related studied concepts. **(3x4 =12)**

18. If in Fig. ,  $R_1 = 10 \Omega$ ,  $R_2 = 40 \Omega$ ,  $R_3 = 30 \Omega$ ,  $R_4 = 20 \Omega$ ,  $R_5 = 60 \Omega$ , and a 12 V battery is connected to the arrangement.

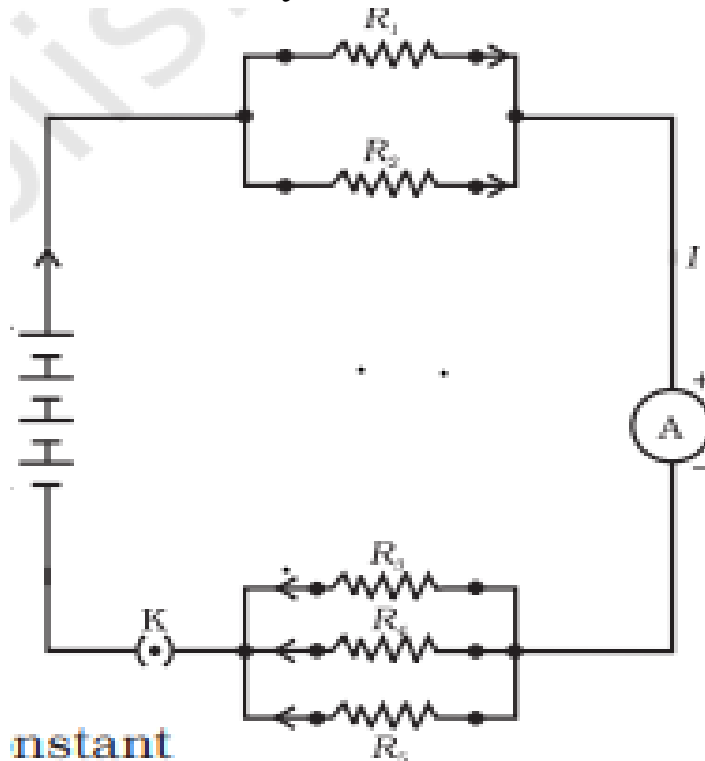

- |  |   |
|--|---|
| Calculate (a) the current through R1 and R5  | 1 |
| (b) the total resistance in the circuit, and | 1 |
| (b) the total current flowing in the circuit | 2 |

Or

What are the advantages of connecting electrical devices in parallel with the battery instead of connecting them in series?

19. The compounds which have the same molecular formula but differ from each other in physical or chemical properties are called isomers and the phenomenon is called isomerism. When the isomerism is due to differences in the arrangement of atoms within the molecule, without any reference to space, the phenomenon is called structural isomerism. In other words, structural isomers are compounds that have the same molecular formula but different structural formulas, i.e., they are different in the order in which different atoms are linked. In these compounds, carbon atoms can be linked together in the form of straight chains, branched chains or even rings.

(i) Which of the following sets of compounds have the same molecular formula? 1

- (a) Butane and iso-butane
- (b) Cyclohexane and hexene
- (c) Propanal and propanone
- (d) All of these

(ii) What must be the minimum number of carbon atoms present in an organic compound in order to form branching? 1

(iii) Draw any two isomers of pentane and name them. 2

20. Question numbers i - iv are based on the table given below. Study the table and answer the following questions.

